

JustBars.Com

Distributed BY
JustCatering.Com Ltd

10 Jessor Avenue, Norwood Green, Midsesex, UB2 5PW, UK

Tel: +44 (0)8750034271 Mobile: 07929291670

E-mail: sales@justcatering.com Web: <http://www.justcatering.com>

BM Top Loading Bottle Coolers
Cooling innovation for bars

imc
fresh thinking

Display, performance, practicality



Designed for underbar use and to compliment our Bartender range of modular underbar systems, the BM range can be integrated perfectly into new or existing Bartender bar runs.

All models are available with unique sliding glass doors to allow contents to be seen without opening. Perfect at busy times when service and stocking are paramount. The reduced opening times for the glass door option help to reduce running costs.



The BM range utilises the latest compressor technology to ensure rapid cooling and constant temperatures whatever the situation.



Conventional storage using optional dividers



Dimensions	H (mm)	W (mm)	D (mm)	Capacity (330ml bottles)
BM70 STD	875	700	560	140
BM70 BT	950	700	560	140
BM100 STD	875	1000	560	210
BM100 BT	950	1000	560	210
BM140 STD	875	1400	560	308
BM140 BT	950	1400	560	308



Rapid cooling times mean that bottled and canned drinks can be chilled and served faster, helping your staff manage customer demand especially at busy periods.

Available with standard front and no splashback the new BM range can be installed in any bar environment.



With a range of shelving and divider options the BM range allows bottles to be stored in the vertical position enabling rapid loading and serving while still maintaining the essential contact with the customer.





The BM range is also available with easy to use baskets, allowing quick and efficient restocking while maintaining greater stock control.



Available in 700mm, 1000mm and 1400mm wide versions, the high quality BM range is supplied in hygienic and extremely durable stainless steel. Ideal for any bar environment.



The Mistral Range

The stylish Mistral bottle coolers can be specified as part of a complete bar solution or individually as required.

For more information please contact IMC.



IMC was founded in 1906 and has since established itself as a leading manufacturer of commercial catering and bar equipment, with a reputation for quality, innovation and unrivalled customer service.



We have the resources, manufacturing expertise, knowledge and skills to provide you with the ultimate bar solutions and we offer complete peace of mind as all of our systems are designed and built to meet BS EN ISO9001: 2000

Imperial Machine Company Limited

Unit 1 Abbey Road
Wrexham Industrial Estate
Wrexham
LL13 9RF
United Kingdom



Specifications are subject to change without notice.

Distributed By

JustCatering.Com Ltd

10 Jessop Avenue, Norwood Green,
Middlesex, UB2 5UY, UK

Tel/Fax: +44 (0)8450034271

Sales: **07929291670**

E-mail: sales@justcatering.com

Web: <http://www.justcatering.com>

VAT number GB 877 7569 45



JustBars.Com

Distributed BY

JustCatering.Com Ltd

10 Jessop Avenue, Norwood Green, Middlesex, UB2 5UY, UK

Tel +44 (0)8450034271 Mobile: 07929291670

E-mail: sales@justcatering.com Web: <http://www.justcatering.com>

Technical Information BM Top Loading Bottle Coolers



August 2008

Overview

The BM range of stainless steel top loading bottle coolers are available in 3 width variations, 700mm, 1000mm and 1400mm with a stainless steel and painted grey mild steel interior. Each cooler comes complete with an innovative shelving system as standard, which allows easy access to the lower storage area.

Designed for underbar use, the BM range can be ordered with either a standard worktop, suitable for any bar environment; or with the optional Bartender® worktop, allowing perfect integration into new or existing bars that feature IMC's Bartender® range of modular stainless steel workstations.

All models feature forced air cooling for rapid and efficient pull down times, while a revolutionary frame design ensures a robust construction, long term reliability and low operating costs.

Product Conformity

BM top loading bottle coolers conform to the following directives:

- Machinery Directive 98/37/EC
- Low Voltage Directive 2006/95/EC
- Electromagnetic Compatibility Directive 2004/108/EC.

Every BM top loading bottle cooler is manufactured in accordance with the following transposed harmonised European Standards:

- EN ISO 12100-1 : 2003, Safety of machinery; basic concepts, general principles for design - Part 1: Basic terminology; methodology
- EN ISO 12100-2 : 2003, Safety of machinery; basic concepts, general principles for design - Part 2: Technical principles and specifications.
- EN 60204-1 : 2006, Safety of machinery; Electrical equipment of machines - Part 1: General requirements
- EN 61000-6-1 : 2001 Electromagnetic compatibility (EMC).
- EN 61000-6-3 : 2001 Electromagnetic compatibility (EMC) - Generic standard. Emission standard for residential, commercial and light-industrial environments

Product Details

Standard Features	Optional Features
<ul style="list-style-type: none"> • Forced air cooling • Parallel sliding doors • Bottle shelves • Bottle opener and catcher • Door locks • Vertical bottle stacking • Electronic controller • Condensate evaporation 	<ul style="list-style-type: none"> • Bartender front and splashback • Glazed doors • Lighting • Bottle baskets • Bottle dividers

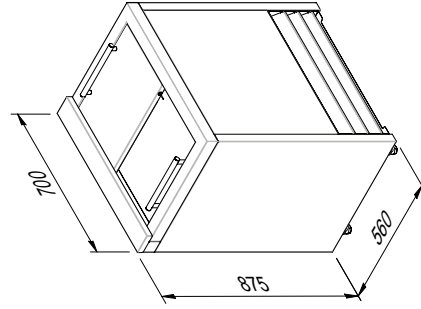

Standard Worktop		BM70 STD	
External Dimensions (h x w x d)	875mm x 700mm x 560mm	External Dimensions (h x w x d)	950mm x 700mm x 560mm
Packing Dimensions (h x w x d)	1100mm x 740mm x 600mm	Packing Dimensions (h x w x d)	1100mm x 740mm x 600mm
Weight (kg) - Unpacked	70	Weight (kg) - Unpacked	70
Weight (kg) - Packed	75	Weight (kg) - Packed	75
Storage Capacity (330 ml Bottles)	140	Storage Capacity (330 ml Bottles)	140
Internal Operating Temp (°C)	+ 4 (±2)	Internal Operating Temp (°C)	+ 4 (±2)
Ambient Temp (°C)	upto + 32	Ambient Temp (°C)	upto + 32
Voltage (Volts)	230	Voltage (Volts)	230
Frequency (Hz)	50	Frequency (Hz)	50
Phase	Single	Phase	Single
Current Draw (Amps)	1.5	Current Draw (Amps)	1.5
Refrigerant Type	R134 A	Refrigerant Type	R134 A
Product Codes	Part No	Product Codes	Part No
Solid Door	F73/070 SS	Solid Door	F73/070 SS
Glazed Door	F73/071 SS	Glazed Door	F73/071 SS
Options	Qty Required	Options	Qty Required
Bottle Basket	4	Bottle Basket	4
Divider Pack	1	Divider Pack	1
Internal Light Pack	1	Internal Light Pack	1

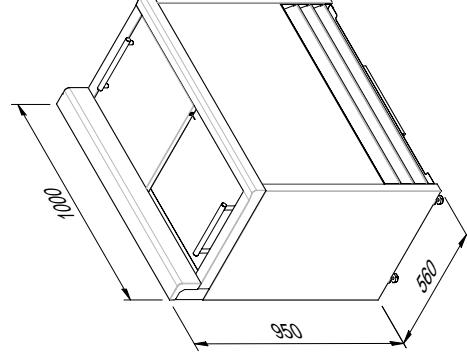
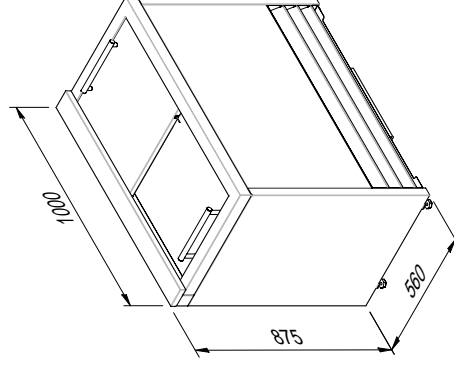
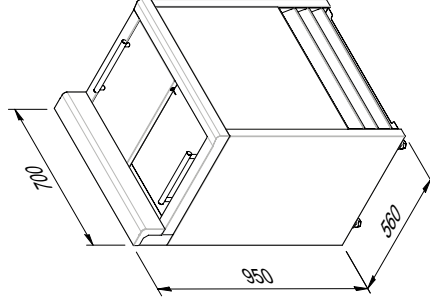

Bartender Worktop		BM70 BT	
External Dimensions (h x w x d)	950mm x 700mm x 560mm	External Dimensions (h x w x d)	950mm x 700mm x 560mm
Packing Dimensions (h x w x d)	1100mm x 740mm x 600mm	Packing Dimensions (h x w x d)	1100mm x 740mm x 600mm
Weight (kg) - Unpacked	70	Weight (kg) - Unpacked	70
Weight (kg) - Packed	75	Weight (kg) - Packed	75
Storage Capacity (330 ml Bottles)	140	Storage Capacity (330 ml Bottles)	140
Internal Operating Temp (°C)	+ 4 (±2)	Internal Operating Temp (°C)	+ 4 (±2)
Ambient Temp (°C)	upto + 32	Ambient Temp (°C)	upto + 32
Voltage (Volts)	230	Voltage (Volts)	230
Frequency (Hz)	50	Frequency (Hz)	50
Phase	Single	Phase	Single
Current Draw (Amps)	1.5	Current Draw (Amps)	1.5
Refrigerant Type	R134 A	Refrigerant Type	R134 A
Product Codes	Part No	Product Codes	Part No
Solid Door	F73/072 SS	Solid Door	F73/072 SS
Glazed Door	F73/073 SS	Glazed Door	F73/073 SS
Options	Qty Required	Options	Qty Required
Bottle Basket	4	Bottle Basket	4
Divider Pack	1	Divider Pack	1
Internal Light Pack	1	Internal Light Pack	1

Standard Worktop		BM100 STD	
External Dimensions (h x w x d)	875mm x 1000mm x 560mm	External Dimensions (h x w x d)	875mm x 1000mm x 560mm
Packing Dimensions (h x w x d)	1100mm x 1040mm x 600mm	Packing Dimensions (h x w x d)	1100mm x 1040mm x 600mm
Weight (kg) - Unpacked	88.5	Weight (kg) - Unpacked	88.5
Weight (kg) - Packed	94	Weight (kg) - Packed	94
Storage Capacity (330 ml Bottles)	210	Storage Capacity (330 ml Bottles)	210
Internal Operating Temp (°C)	+ 4 (±2)	Internal Operating Temp (°C)	+ 4 (±2)
Ambient Temp (°C)	upto + 32	Ambient Temp (°C)	upto + 32
Voltage (Volts)	230	Voltage (Volts)	230
Frequency (Hz)	50	Frequency (Hz)	50
Phase	Single	Phase	Single
Current Draw (Amps)	1.6	Current Draw (Amps)	1.6
Refrigerant Type	R134 A	Refrigerant Type	R134 A
Product Codes	Part No	Product Codes	Part No
Solid Door	F73/100	Solid Door	F73/100
Glazed Door	F73/101	Glazed Door	F73/101
Options	Qty Required	Options	Qty Required
Bottle Basket	6	Bottle Basket	6
Divider Pack	1	Divider Pack	1
Internal Light Pack	1	Internal Light Pack	1

Bartender Worktop		BM100 BT	
External Dimensions (h x w x d)	950mm x 1000mm x 560mm	External Dimensions (h x w x d)	950mm x 1000mm x 560mm
Packing Dimensions (h x w x d)	1100mm x 1040mm x 600mm	Packing Dimensions (h x w x d)	1100mm x 1040mm x 600mm
Weight (kg) - Unpacked	88.5	Weight (kg) - Unpacked	88.5
Weight (kg) - Packed	94	Weight (kg) - Packed	94
Storage Capacity (330 ml Bottles)	210	Storage Capacity (330 ml Bottles)	210
Internal Operating Temp (°C)	+ 4 (±2)	Internal Operating Temp (°C)	+ 4 (±2)
Ambient Temp (°C)	upto + 32	Ambient Temp (°C)	upto + 32
Voltage (Volts)	230	Voltage (Volts)	230
Frequency (Hz)	50	Frequency (Hz)	50
Phase	Single	Phase	Single
Current Draw (Amps)	1.6	Current Draw (Amps)	1.6
Refrigerant Type	R134 A	Refrigerant Type	R134 A
Product Codes	Part No	Product Codes	Part No
Solid Door	F73/102	Solid Door	F73/102
Glazed Door	F73/103	Glazed Door	F73/103
Options	Qty Required	Options	Qty Required
Bottle Basket	6	Bottle Basket	6
Divider Pack	1	Divider Pack	1
Internal Light Pack	1	Internal Light Pack	1

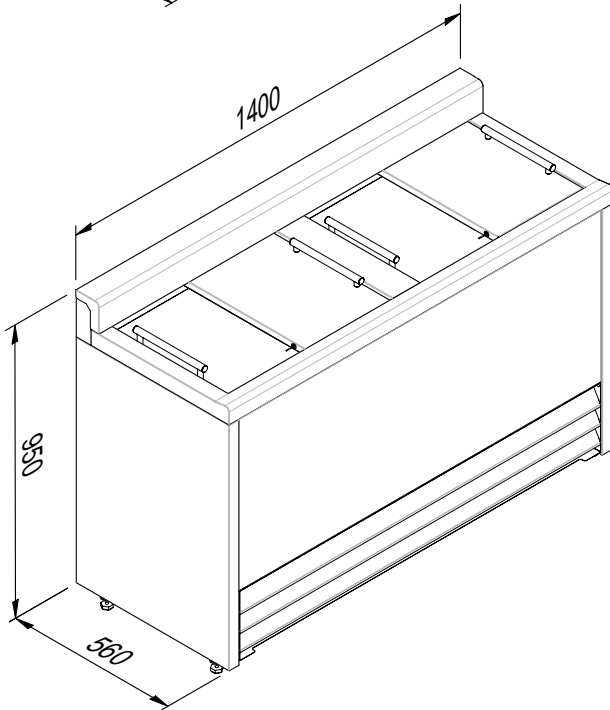
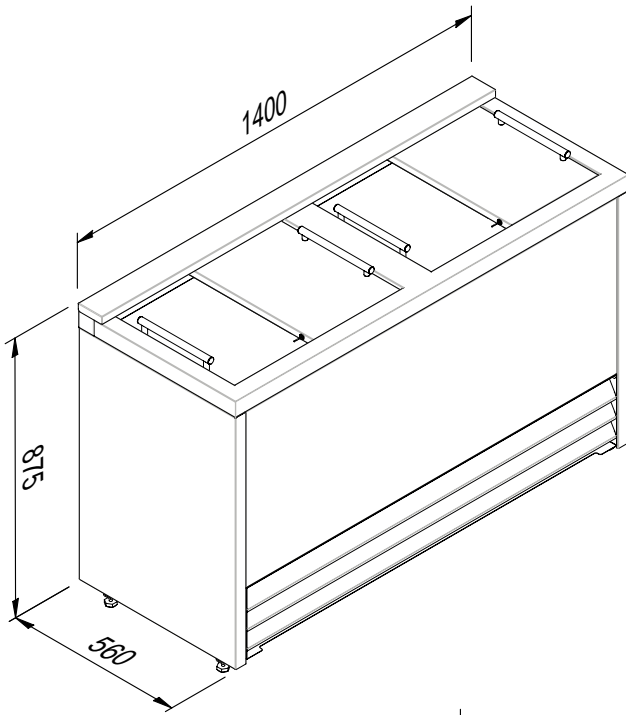

Standard Worktop	BM140 STD	
External Dimensions (h x w x d)	875mm x 1400mm x 560mm	
Packing Dimensions (h x w x d)	1100mm x 1440mm x 600mm	
Weight (Kg) - Unpacked	113	
Weight (Kg) - Packed	120	
Storage Capacity (330 ml Bottles)	308	
Internal Operating Temp (°C)	+ 4 (±2)	
Ambient Temp (°C)	upto + 32	
Voltage (Volts)	230	
Frequency (Hz)	50	
Phase	Single	
Current Draw (Amps)	1.75	
Refrigerant Type	R134 A	
Product Codes		
	Part No	
Solid Door	F73/140	
Glazed Door	F73/141	
Options		
	Qty Required	Part No
Bottle Basket	10	A12/089
Divider Pack	1	S73/210
Internal Light Pack	1	VS322

Bartender Worktop	BM140 BT	
External Dimensions (h x w x d)	950mm x 1400mm x 560mm	
Packing Dimensions (h x w x d)	1100mm x 1440mm x 600mm	
Weight (Kg) - Unpacked	113	
Weight (Kg) - Packed	120	
Storage Capacity (330 ml Bottles)	308	
Internal Operating Temp (°C)	+ 4 (±2)	
Ambient Temp (°C)	upto + 32	
Voltage (Volts)	230	
Frequency (Hz)	50	
Phase	Single	
Current Draw (Amps)	1.75	
Refrigerant Type	R134 A	
Product Codes		
	Part No	
Solid Door	F73/142	
Glazed Door	F73/143	
Options		
	Qty Required	Part No
Bottle Basket	10	A12/089
Divider Pack	1	S73/210
Internal Light Pack	1	VS322

Notes

Imperial Machine Company Limited

Unit 1 Abbey Road
 Wrexham Industrial Estate
 Wrexham
 LL13 9RF
 United Kingdom



Specifications are subject to change without notice.

Distributed By

JustCatering.Com Ltd

10 Jessop Avenue, Norwood Green,
 Middlesex, UB2 5UY, UK

Tel/Fax: +44 (0)8450034271

Sales: **07929291670**

E-mail: sales@justcatering.com

Web: <http://www.justcatering.com>

VAT number GB 877 7569 45