



F49/400/BS - IMC Frostar FR60 Glass Froster [Top Load] - Black Exterior - W 600 mm - 0.650 kW

Stylish and functional, the Frostar FR60 is designed to frost glasses and super-chill spirits, keeping drinks colder for longer and enhancing their appearance.

- ✓ Chills and frosts glasses, to enhance the taste and appearance of drinks
- ✓ Top loading with sliding cover for quick and easy access
- ✓ Rapid chill to -17°C to keep drinks colder for longer
- ✓ Stylish stainless steel exterior to suit any commercial bar setting
- ✓ Efficient design means up to 75 glasses can be chilled at the same time
- ✓ UK 3 pin plug - simply plug in and switch on.

Specifications

Summary

Brand	IMC
Range	Frostar
Power Type	Electric
Unit Type	Free-standing
Available in UK Only	No
UK Warranty	2 Years Parts and Labour Warranty
Export Warranty	Contact your local dealer
GTIN	5056105198567

Power and Performance

Total Power kW	0.650
Temperature Range °C	-17 constant
IP Rating	IPX1
Temperature Control	Electronic

Key Specifications

Door Hinge	Sliding
Door Location	Top
Lockable Door	Yes
Colour	Black
Number of Doors	1
Number of Shelves included	3
Number of Shelf Positions	2
Refrigerant Type	R452a
Type of Lighting	Fluorescent

Capacity

Capacity Glasses	75 x standard pint
Capacity Litres	132

Weights and Dimensions

Unit Height (External) mm	900
Unit Width (External) mm	600
Unit Depth (External) mm	620
Height (Internal) mm	550
Width (Internal) mm	526
Depth (Internal) mm	460
Shelf Dimensions Width mm	520 [bottom], 300 [top]
Shelf Dimensions Depth mm	450
Net Weight Kg	56.5

Supply Connections

Requires Installation	No
Requires Electrical Supply	Yes
UK 3 Pin Plug	Yes
Requires Hardwiring	No
Electrical Supply Rating Watts	650
Single Phase Amps	2.71
Single Phase Voltage	240

Shipping

Packed Weight Kg	62.15
Packed Height cm	105
Packed Width cm	68
Packed Depth cm	68

Available Accessories

Available Accessories

S49/017

Bottle Opener and Cap Catcher for FR60/90 Glass Froster

Technical Picture

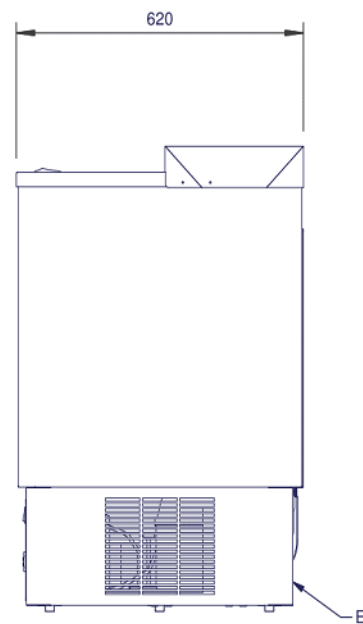
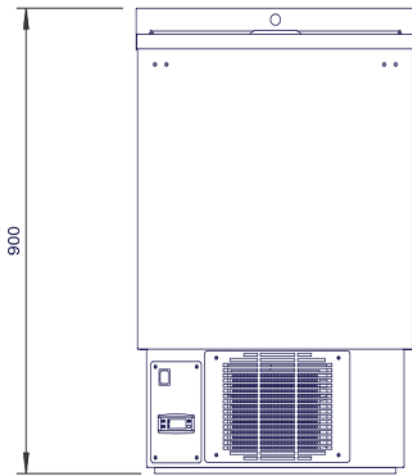
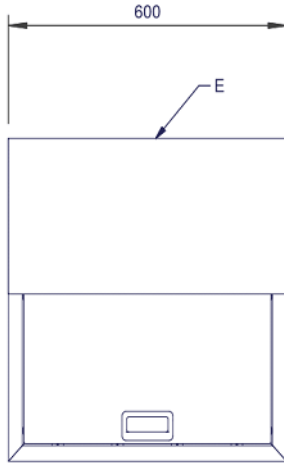



Lincat Limited

Whisby Road,
Lincoln, LN6 3QZ,
United Kingdom

Company No: 2175448

A member company of



Customer Care

Tel: +44 1522 875500
Email: care@lincat.co.uk

Export Customers

Tel: +44 1522 875536
Email: export@lincat.co.uk

Opening Hours

Monday – Friday:
8.30am – 5pm